

What Are The Classifications Of Soy Protein?

The fully automatic soy protein extruder uses heating, extrusion, puffing and other processes to produce "plant meat" that has the shape, taste and taste similar to real animal meat. And this program has been relatively mature, and has begun to spread rapidly around the world.

What are popular in our food machinery industry circle in 2020? In addition to instant rice is vegetable protein meat! This is an era of advocating healthy vegetarian food! Plant-based artificial meat should become a new outlet product in the market!



Just in May of this year, the meat brand Jinluo launched a new series of vegetable meat products "Vegetarian Pie"!

The so-called vegetable meat, also known as protein meat or artificial meat, is the use of modern food technology. Extract vegetable protein from various plants (such as peanut protein powder, soybean, wheat protein, etc.). The fully automatic soy protein extruder uses heating, extrusion, puffing and other processes to produce "plant meat" that has the shape, taste and taste similar to real animal meat. And this program has been relatively mature, and has begun to spread rapidly around the world.

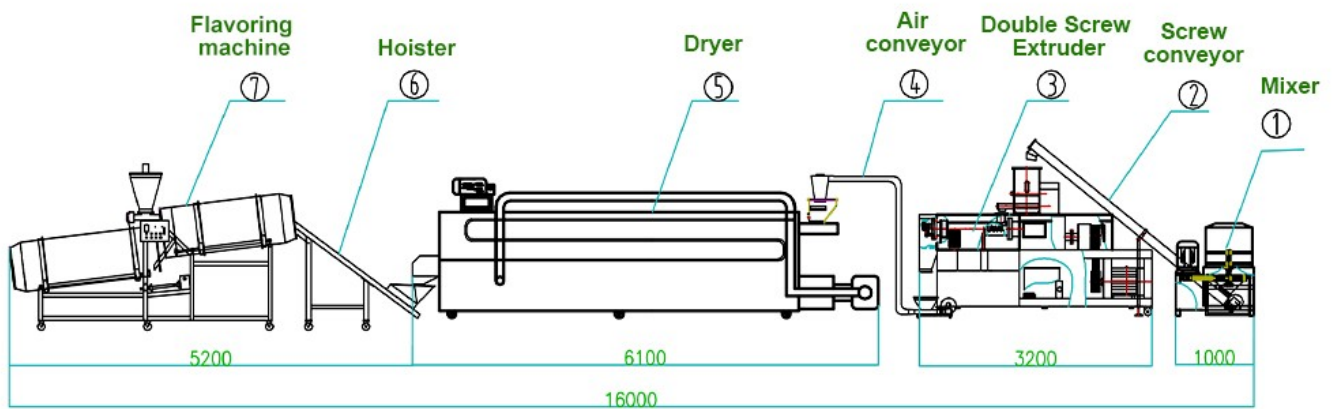

The classification and application range of vegetable protein meat is very wide. From the perspective of our Shandong Loyal company in the machinery industry, it can be divided into: tissue protein, drawing protein and high humidity protein! From the perspective of application customers, vegetable meat can be used for vegetarian dumplings, vegetarian burgers, vegetarian steaks, hot pot meatballs, ham sausages and other vegetarian meat products you might not think of!



The vegetable protein vegetarian meat that is close to the taste of real meat requires high processing technology and equipment. The extrusion host in the Shandong Loyal soybean protein production line has been constantly innovating and upgrading! The protein raw material receives the action of shear and friction in the extruder. The adjacent linear protein molecules inside attract each other and tend to combine! When the material is squeezed through the mold, the effect of higher shear force and directional flow. Promote the linearization, fibrosis, and linear arrangement of protein molecules. In this way, the extruded protein forms a silky protein with a certain fiber and porous structure. The higher the protein content, the stronger the fiber feel. According to specific output, different extruder models can be recommended! We have professional engineers who can tailor solutions for you!

